

TREK-510

NEW



ARM-based, In-Vehicle Computing Box

Features

- ST ARM based STA2062 333 MHz CPU with Win CE
- Automotive grade working temperature range (-30 to 70° C)
- Rich I/O such as CAN, multi-COMs, isolation 4DI/4DO, line out, Mic in, USB, SD
- Built-in RF communication modules, such as GPRS/HSDPA/CDMA
- Certifications: CE, FCC, E-mark and MIL-STD-810G, ISO7637-2, SAE J1113, SAE J1455 regulations
- Ignition on/off delay; SW detectable/controllable for car power management



Introduction

The TREK-510 is a dedicated box computer for industrial vehicle fleets, transport trucks, buses and taxis. TREK-510 combined with a variety of I/O connectors can be connected to devices like OBD-II or TPMS (Tire Pressure Monitoring System).

Built-in wireless communications-WWAN enable TREK-510 to send important driver/vehicle/location/car information back to the control center. TREK-510 can also operate in extreme environments with features like a wide working temperature range (-30 to 70 degrees) and anti-shock/vibration design. TREK-510 also uses a special design to handle the critical issue of in-vehicle power. Special power protection (ISO7637-2/SAE J1455 Class A/ SAE J1113) and car power management software (Ignition on/off, delay on/off, low battery monitor) prevent electrical noise and surges from impacting the system, guarding against damage from transient car power.

Specifications

System	Soc	STM industrial degree STA2062 ARM9-based 333 Mhz RISC SOC	
	System Memory	Mobile DDR 128 MB	
	Watchdog	Yes	
	RTC	Yes, with one time 200 mAh coin battery	
Physical	Operating System	Win CE 5.0 English core version as default	
	Dimensions	261 x 125 x 59.1 mm	
	Weight	1.5 kg	
Storage	On Board Flash	2 GB on board flash for bootloader, image & Customer's AP	
	SD slot	1 x (external accessible)	
Display Interface	Smart Display Port	Design compatible with TREK-303L, 7" smart display, the signal includes:	
		- 18-bit LVDS out - 1 x RS-232 - 1 x audio line out - 1 x USB Host - 12 V @ 1 A output	
I/O	CAN	1 x CAN 2.0 A/B by DB9 with J1939 protocol	
	USB Host	1 x USB 2.0 host port by type A	
	USB Client	1 x USB Client by Mini Type AB	
	Mic In	1 x RCA jack	
	Line-out	1 x RCA jack	
	COM Port	COM 1&2: 2 x Full Function RS-232, 5 V/12 V @ 0.5 A, ping9, by jumper selection COM3: 1 x 4-wire RS-232/485 (controlled by software), 5 V/12 V @ 0.5 A, ping9, by jumper selection	
Communication	WWAN	4 x Isolated dry contact digital inputs from DB9 connector (2500 Vrms protection)	
		4 x relay driver from DB9 connector	
GPS	RF Receiver Type	32 Channels (built-in), GPS L1 frequency, C/A code	50 channels, GPS L1 frequency (option)
		Cold Start	39 s
	Warm Start	33 s	29 s
	Hot Start	< 1 s	< 1 s
	AGPS	3 s	< 5 s
	Acquisition	-145dBm	-160dBm
	Protocol	NMEA Input/output, ASCII, 0183, 2.3 (compatible to 3.0)	
	Antenna	SMA connector for external antenna	
LED	LED indicator	Power (Red), GPS operation (Blue), WWAN link (Green), Status (Green)	

TREK-510

Specifications Cont.

Car Power Design	DC-Input	Supports 12/24V car power systems (6V ~ 36V wide DC input, ISO 7637, SAE J1113)
	Power Management	Power on/off delay, Power on delay, 2 sec by default Power off delay, 5 sec by default Delay time allow control by SW configuration Low voltage protection
Environment	HW Reset	Yes, 1 reset button
	IP rating	IP31
	Operating Temp.	-30° C ~ +70° C
	Storage Temp.	-40° C ~ +85° C
Certifications	Vibration/shock	MIL-STD-810G, Method 516.5
	EMC	CE, FCC
	Safety	CE, CB
Mechanical	Vehicle Power Regulations	E-mark, SAE J1455, SAE J1113, ISO7637-2, compliance
	Material	Top cover (Aluminum extrusion) Side cover (PC) Bottom & I/O cover (metal)

Dimensions

Unit: mm

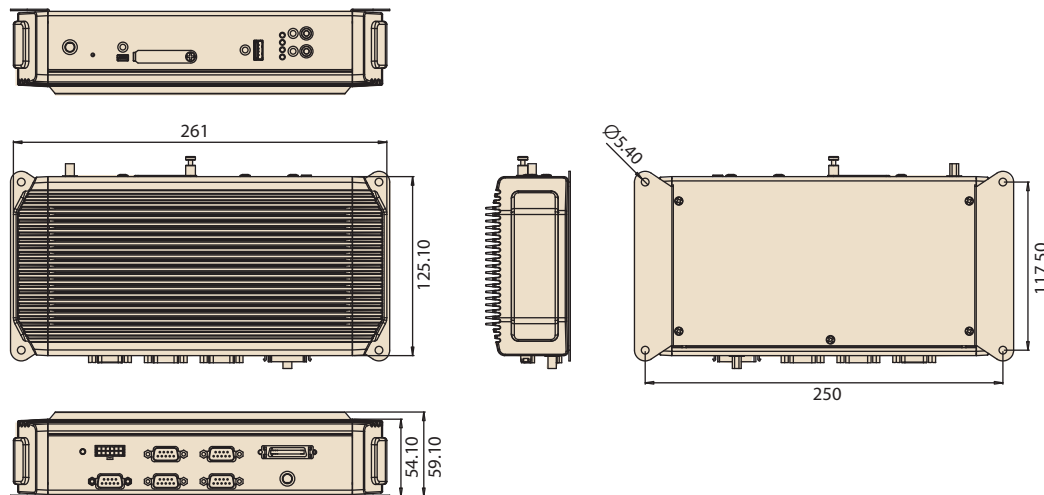

Ordering Information

Part Number	Description
TREK-510-GCEAOE	Vehicle computing system with ST 2062 processor, 128 MB RAM and 2 GB NAND flash, GPS, GPRS, Win CE 5.0
TREK-303R-LA0E	7" vehicle display system, 480 x 234 resolution, with 4 wire resistive touchscreen, 2-watt speaker
1700018342	2-meter cable (paired with TREK-510)

Packing List

Part Number	Description	Quantity
TREK-510-GCEAOE	ARM-based, in-vehicle computing box	x1
1700018306	Power cable	x1
1750001380	GPS Antenna	x1
1750006080	WWAN Antenna	x1
2068051000	Startup manual CD	x1
19900018848T000	Cable clip for MIC in, line out, USB host, USB client	x4

Fully Integrated I/O

